



WET LOCATION EXIT SIGN

INSTALLATION, OPERATION & MAINTENANCE INSTRUCTIONS

READ AND FOLLOW ALL SAFETY INSTRUCTIONS

IMPORTANT SAFEGUARDS: When using electrical equipment, always adhere to basic safety precautions including the following:

1. Do not mount near gas or electric heaters.
2. Equipment should be mounted securely in locations and at heights where it will not be readily subjected to tampering by unauthorized personnel.
3. The use of accessory equipment and replacement parts not recommended by the MANUFACTURER may cause an unsafe condition.
4. Do not use this equipment for other than its intended purpose.
5. The AC voltage rating of this equipment is specified on the product label. Do not connect equipment to any other voltage.

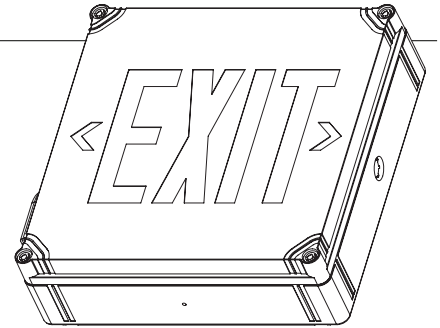

SAVE THESE INSTRUCTIONS!

INSTALLATION INSTRUCTIONS

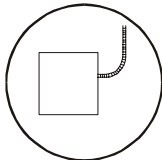
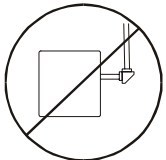

FLEXIBLE CONDUIT ONLY!

1. Mount the equipment securely in place. The provided (4) mounting screws and (4) anchors are for mounting to surfaces suitable for use of such hardware as Stucco, Concrete, or similar surfaces. If mounting to surfaces where machine type screws and anchors (such as toggle bolts) or other types of anchoring hardware will be necessary, this hardware must be provided in the field by the installer. Consult factory for assistance if needed.
2. Extend 24-hour AC supply of rated voltage to the equipment, which is furnished with a dual voltage 120V/277V field selectable input (see Figure 1 on page 2). Connect unit to utility power using an approved seal tight connector or NEMA4X connector. The unit should be DRILLED for the connector in the proper location as it relates to the location of the entry point of the power feed coming into the unit. There are various places inside the unit that are suitable for this incoming power location. For 120V supply, connect the line wire to the black lead for 277V supply, connect the line wire to the orange/red lead. Connect neutral wire to the white lead. Connect the ground wire in accordance with local codes. **DO NOT** energize circuit at this time.
CAUTION: Insulate the unused black or orange wire. Failure to insulate the unused wire will cause an unsafe condition.
3. Connect battery (for battery backup units). The equipment is supplied with one battery lead (red + positive), connected. If the battery is supplied with terminals, connect the blue battery lead to the negative terminal. If the battery is supplied with leads, connect the two blue leads together with the supplied wire nut. If the battery is supplied with a connector, plug it into the mate on the LED strip.
4. Energize the AC supply. The **CHARGE** indicator will illuminate.
5. Replace the cover.

OPERATION (for battery backup unit)

1. To test the equipment, depress the TEST switch. The CHARGE indicator will go out and the LED lights inside the unit will continue to illuminate.
2. Release the TEST switch. The CHARGE indicator will illuminate. The automatic charger will return and maintain the battery in a fully charged state.

NOTE: Allow the battery to charge for a minimum of 24 hours after installation or after a power failure before conducting a 90 minute test (see TESTING section). **CAUTION:** This equipment is furnished with a sophisticated solid state transfer switch which will automatically disconnect the LED lights from the battery if the battery has been discharged to the end of its useful output.

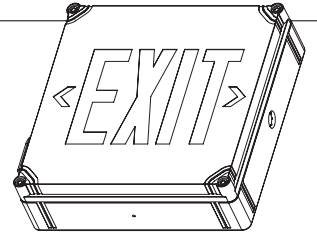

MAINTENANCE

CAUTION: Always turn off AC power to the equipment before servicing. Servicing should only be performed by a qualified service technician. Use only MANUFACTURER-supplied replacement parts.

1. **BATTERY** (for battery backup unit): The battery supplied in this equipment requires no maintenance. However, it should be tested periodically (see TESTING section) and replaced when it no longer operates the connected fixtures for the duration of a 30-second or 90-minute test. The battery supplied in this equipment has a life expectancy of 5-7 years when used in a normal ambient temperature of 72°F.
2. **OTHER:** Clean lenses and replace lamps as required.

TESTING (for battery backup unit)

Paragraph 31-1.3.7 of NFPA 101-1985, Life Safety Code requires that all emergency lighting equipment be functionally tested every 30 days for a minimum of 30 seconds and tested yearly for a full 90-minute duration. Written records of testing are to be kept for examination by the authority having jurisdiction.

TROUBLE-SHOOTING (for battery backup unit)

1. The LED lights are not illuminating.
 - a. If the charge indicator light is off: check that the circuit breaker for the AC supply is on.
 - b. If the charge indicator light is on:
 - check that the battery is properly connected.
 - if problem persists, replace battery.
2. LED lights are dim: battery is not fully charged. Allow battery to recharge for 24 hours and then re-test. If lights are still dim, replace battery.

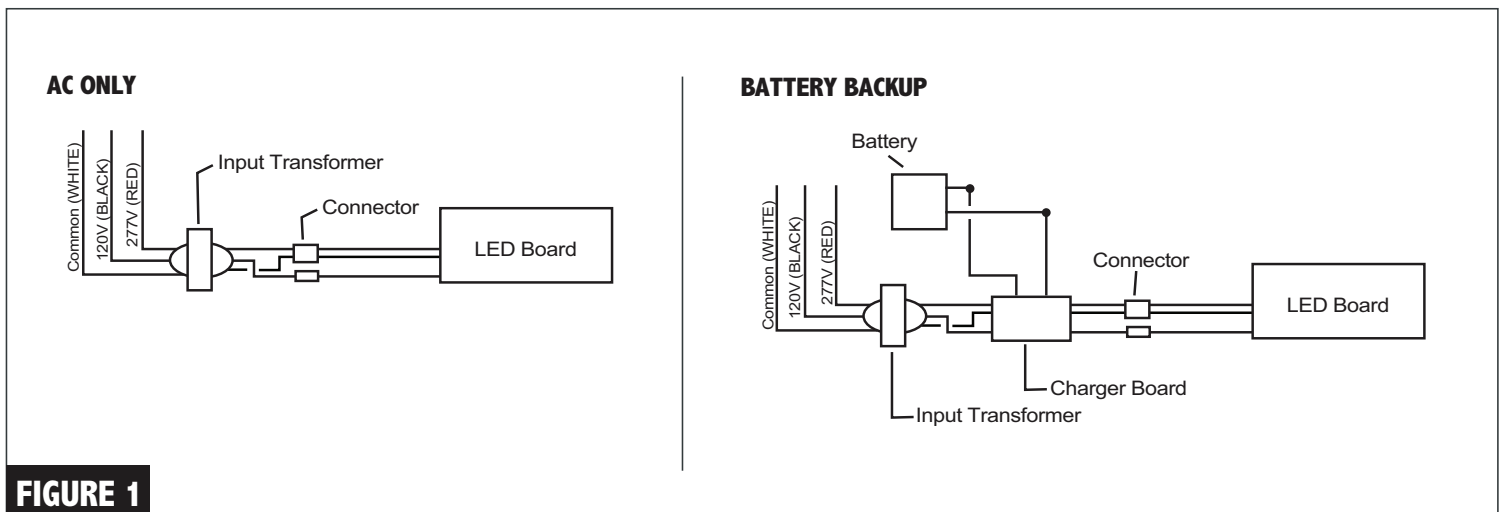

FIGURE 1

WARNING: UNUSED WIRES MUST BE CAPPED USING ENCLOSED WIRE NUTS.