

# LED WET LOCATION EMERGENCY UNIT INSTALLATION, OPERATION & MAINTENANCE INSTRUCTIONS

## READ AND FOLLOW ALL SAFETY INSTRUCTIONS

IMPORTANT SAFEGUARDS: When using electrical equipment, always adhere to basic safety precautions including :

1. Do not mount near gas or electric heaters.
2. Equipment should be mounted securely in locations and at heights where it will not be readily subjected to tampering by unauthorized personnel.
3. The use of accessory equipment and replacement parts not recommended by the MANUFACTURER may cause an unsafe condition.
4. Do not use this equipment for other than its intended purpose.
5. The AC voltage rating of this equipment is specified on the product label. Do not connect equipment to any other voltage.
6. In unheated areas where the temperature may drop below 32°F for prolonged periods, the battery capacity and total output rating of the equipment will be reduced. Ensure that the equipment will operate in conformance with the applicable National Electric Code and NFPA Life Safety code requirements. Contact manufacturer for further technical assistance.

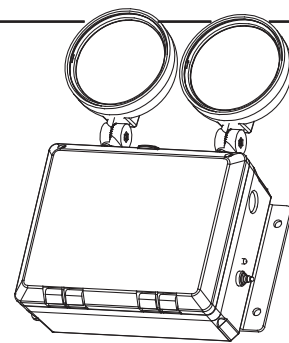

## SAVE THESE INSTRUCTIONS!

### INSTALLATION INSTRUCTIONS

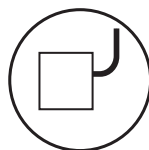
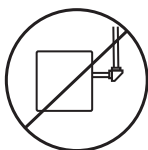

**FLEXIBLE CONDUIT ONLY!**

1. Mount the equipment securely in place using the hardware provided and the mounting tabs on the back of the housing. If accessory mounting devices are being utilized in this installation, follow any instructions provided with those devices to ensure a safe installation.
2. Extend 24-hour AC supply of rated voltage to the equipment, which is furnished with a dual voltage 120V/277V field selectable input (see Figure 1 on page 2). The unit should be DRILLED for the connector in the proper location as it relates to the location of the entry point of the power feed coming into the unit. There are various places inside the unit that are suitable for this incoming power location. For 120V supply, connect the line wire to the black lead. For 277V supply, connect the line wire to the red lead. Connect neutral wire to the white lead. Connect the ground wire in accordance with local codes. A green ground lead is provided. **DO NOT** energize circuit at this time.  
**CAUTION:** Insulate the unused black or orange wire. Failure to insulate the unused wire will cause an unsafe condition.
3. Connect the battery to the circuit board after the unit is installed.
4. Energize the AC supply. The **CHARGE** indicator will illuminate.
5. Replace the cover.
6. Adjust and focus the lighting heads as required.

**CAUTION: If conduit is applied, use UL Listed Suitable for Wet Location parts.**

## OPERATION

1. To test the equipment, depress the TEST switch. The CHARGE indicator will go out and the emergency lights will illuminate.
2. Release the TEST switch, the emergency lights will go out and the CHARGE indicator will illuminate. The automatic charger will return and maintain the battery in a fully charged state.

NOTE: Allow the battery to charge for a minimum of 24 hours after installation or after a power failure before conducting a 90 minute test (See TESTING section). CAUTION: This equipment is furnished with a sophisticated solid state transfer switch which will automatically disconnect the emergency lights from the battery if the battery has been discharged to the end of its useful output.

## MAINTENANCE

CAUTION: Always turn off AC power to the equipment before servicing. Servicing should be performed only by a qualified service technician. Use only MANUFACTURER supplied replacement parts.

1. BATTERY: the battery supplied in this equipment requires no maintenance. However, it should be tested periodically (see TESTING section) and replaced when it no longer operates the connected fixtures for the duration of a 30 seconds or 90 minute test. The battery supplied in this equipment has a life expectancy of 4-5 years when used in a normal ambient temperature of 72°F.
2. OTHER: Clean lenses as required.

## TESTING

Paragraph 31 – 1.3.7 of NFPA 101 – 1985, Life Safety Code requires that all emergency lighting equipment be functionally tested every 30 days for a minimum of 30 seconds and tested yearly for a full 90 minute duration. Written records of testing are to be kept for examination by the authority having jurisdiction.

## TROUBLE-SHOOTING

1. The emergency lights do not operate.
  - a. If the charge indicator light is OFF: check that the circuit breaker for the AC supply is ON.
  - b. If the charge indicator light is ON:
    - check that the battery is properly connected
    - and remote lamp heads are connected to equipment, turn OFF AC supply and disconnect remote circuit wires from equipment. Turn ON AC supply and depress the test switch. If equipment-mounted lamp heads are now ON, check remote circuit for short or overload condition and correct as required. Then reconnect circuit wires and restore AC power.
    - If problem persists, replace battery.
2. Emergency lights are dim: battery is not fully charged. Allow battery to recharge for 24 hours and then re-test. If lights are still dim, replace battery

Figure 1.

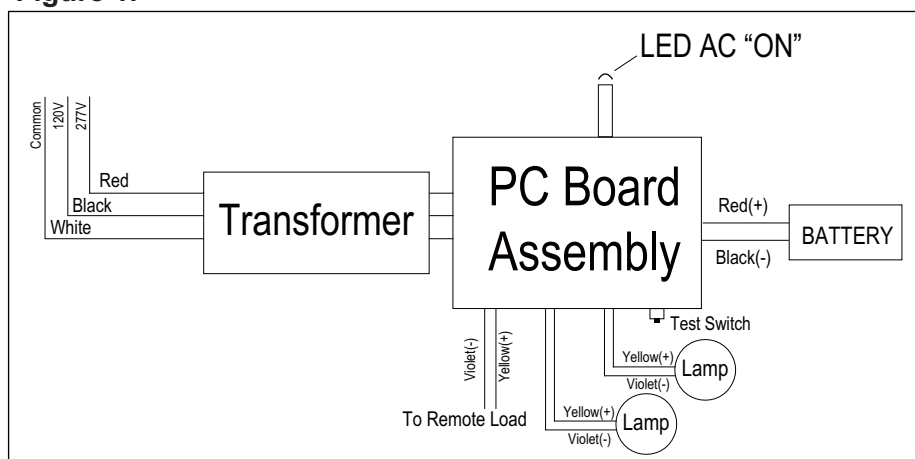

**WARNING:**  
**UNUSED WIRES MUST**  
**BE CAPPED USING**  
**ENCLOSED WIRE NUTS.**