

INSTALLATION INSTRUCTIONS

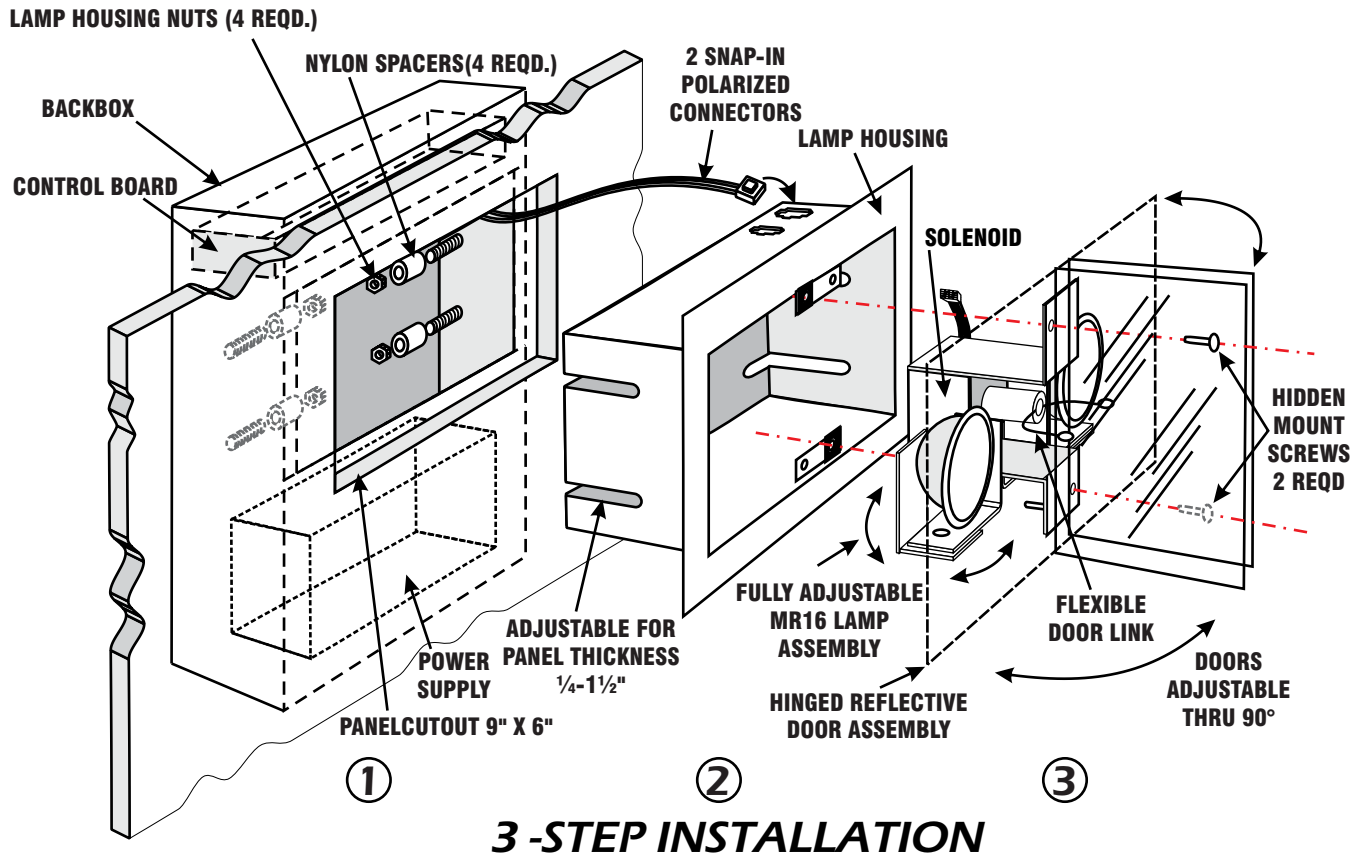

IMPORTANT SAFEGUARDS READ AND FOLLOW ALL SAFETY INSTRUCTIONS

Before connecting to power supply, **TURN OFF ELECTRICAL POWER AT CIRCUIT BREAKER OR FUSE**

Disconnect generator line AC power before servicing.

Refer to wiring diagram for proper connections.

All servicing should be performed by qualified personnel.

Consult your local building code for approved wiring and installation.

Do not use outdoors.

Do not use this equipment for other than intended use.

Suitable for indoor damp locations.

Do not let power cords touch hot surfaces.

Do not mount near gas or electric heaters.

Mount and secure the fixture at a location and height to avoid ready access and tampering by unauthorized persons.

The use of accessory equipment is not recommended by the manufacturer and may cause an unsafe condition.

SAVE THESE INSTRUCTIONS

TOP MOUNT

Backbox Installation

REV 12.21.2

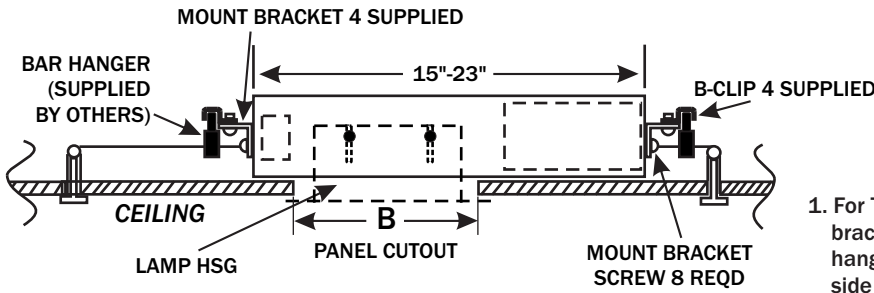

1. For T-Bar installations, rotate side bracket clips as required to fit T-Bar hangers. For masonry ceilings, attach side brackets to beam.

2. Refer to table on Page 2 and make cutout in ceiling panel.

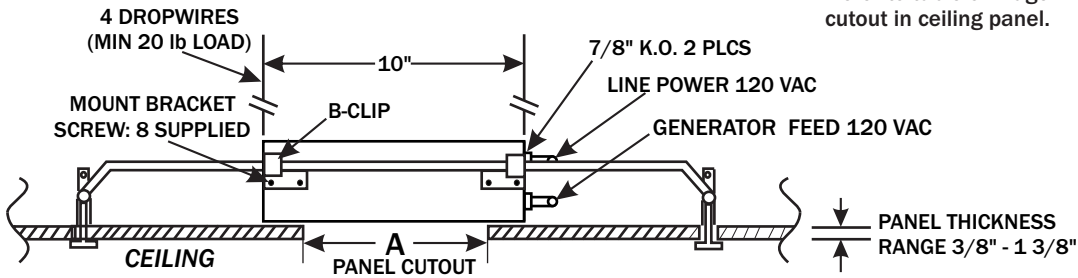

BACKBOX MUST BE FLUSH WITH TOP (INSIDE) SURFACE. IN MASONRY CEILINGS, SUPPORT WITH DROP WIRES AND FRAMING AS REQUIRED

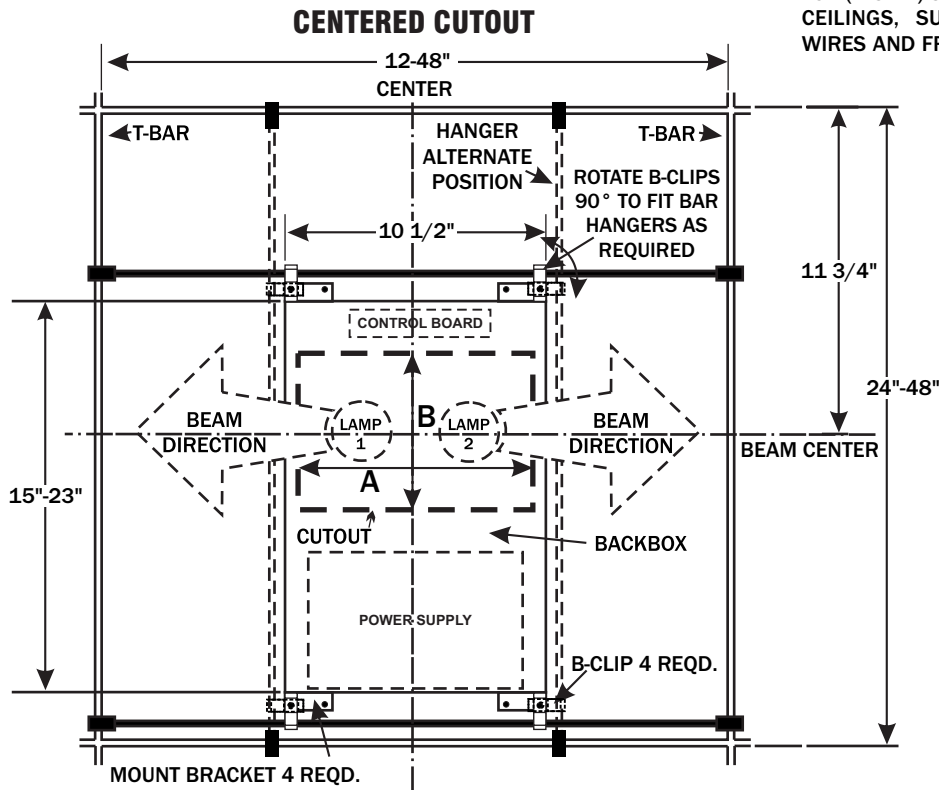

WALL MOUNT

Backbox Installation

REV 12.21.2

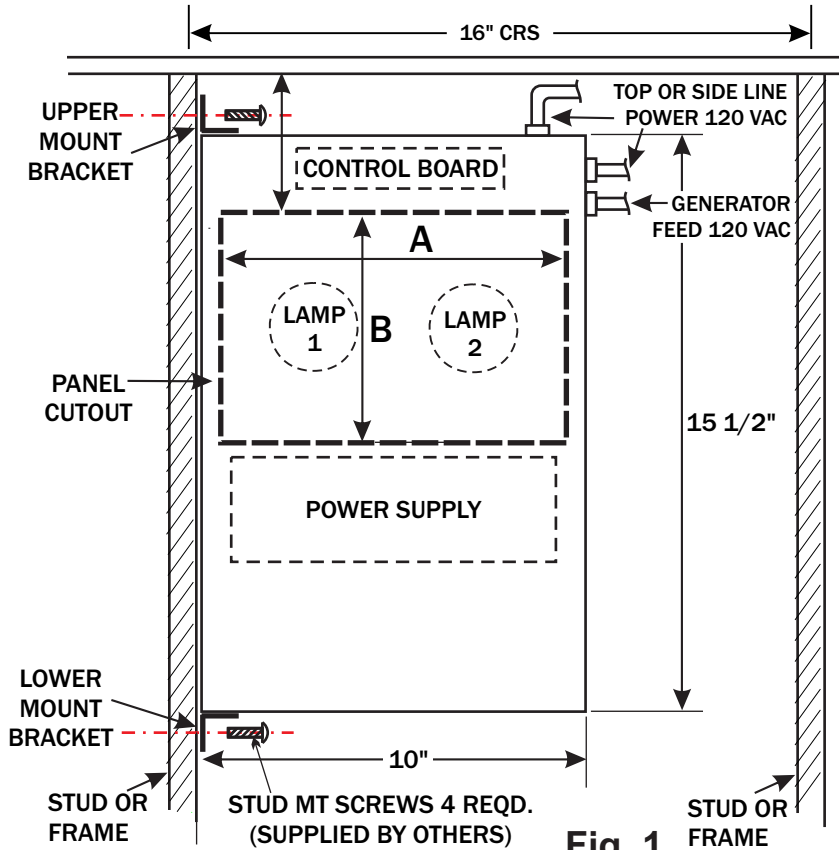

Fig. 1

1. Backbox mounts to stud on either left or right side. Select side to mount and attach upper and lower mount brackets with (4) #6-32 sheet metal screws provided.

2. See Table 1 below. Determine panel cutout location desired. Place backbox into position with face **flush or just below stud face**. Mark mount bracket hole locations. **NOTE:** Upper bracket holes should be a minimum of 3" from upper joist or ceiling panel.

3. Drill pilot holes in stud at marked locations, and mount backbox in position with (4) mount screws installed firmly.

Both upper and lower mount brackets must be used. Fixture weight may be up to 15 lbs.

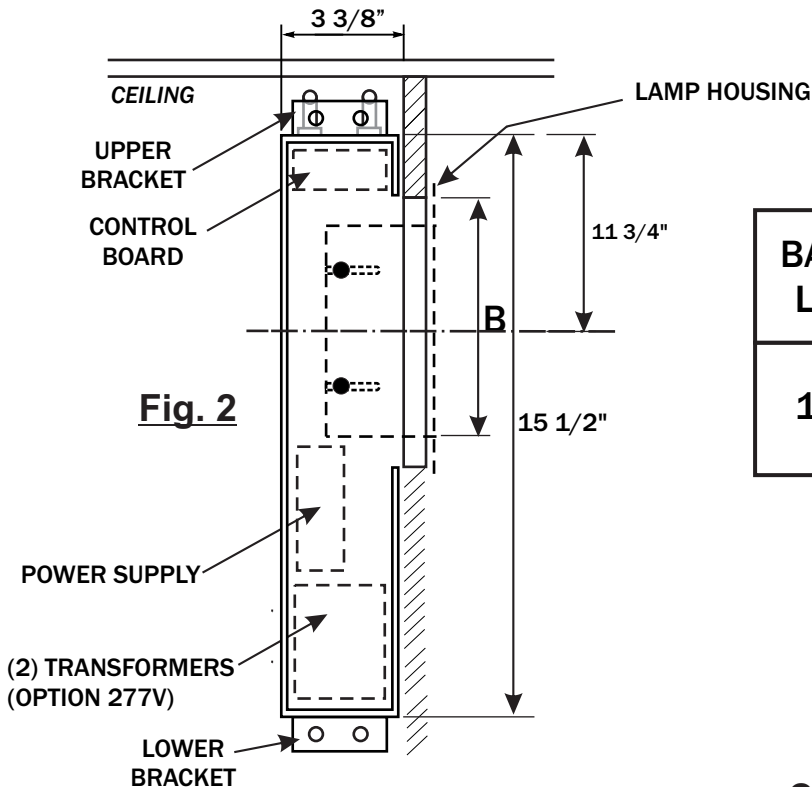

Fig. 2

Table 1

BACKBOX LENGTH	PANEL CUTOUT	
	A	B
15 1/2"	9"	6"

Installation Instructions

REV 12.21.2

BEFORE INSTALLING OR CONNECTING PRIMARY & GENERATOR POWER WIRING, DISCONNECT MAIN AND GENERATOR POWER AT CIRCUIT BREAKERS.

POWER SUPPLY & CONTROL BOARD ASSEMBLY: WALL OR CEILING MOUNT

1. See Fig. 1. Route Line and Neutral 120 VAC or 277VAC normal and generator input power wiring into back box (4 wires).
2. Install 7/8" connector and connect to power supply with standard wire nuts as shown. Place ground connector on stud and tighten down:
BLACK: 120 VAC WHITE: Neutral GREEN: Ground
ORANGE: 277 VAC WHITE: Neutral GREEN: Ground
3. Position AC leads and wire nuts at side of control board clear of output DC wiring.

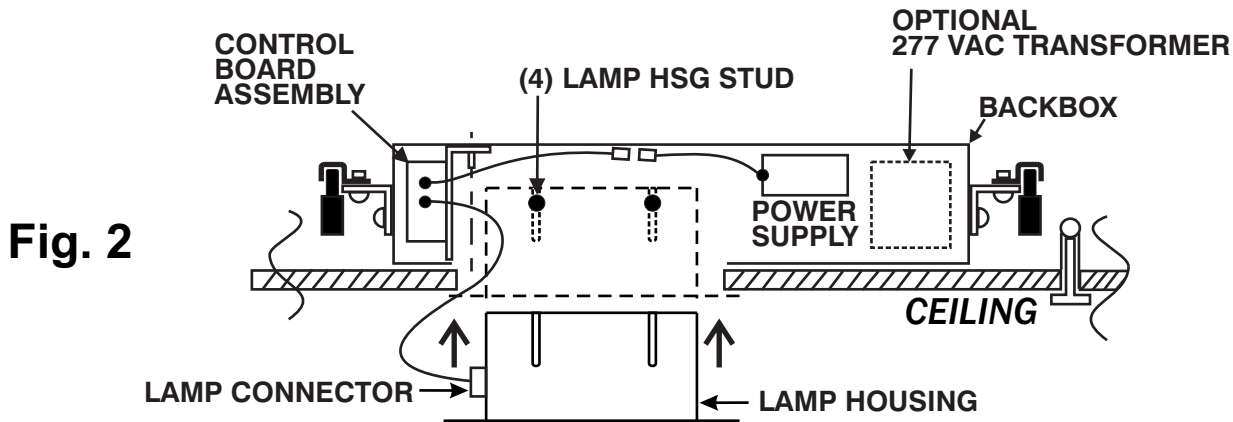
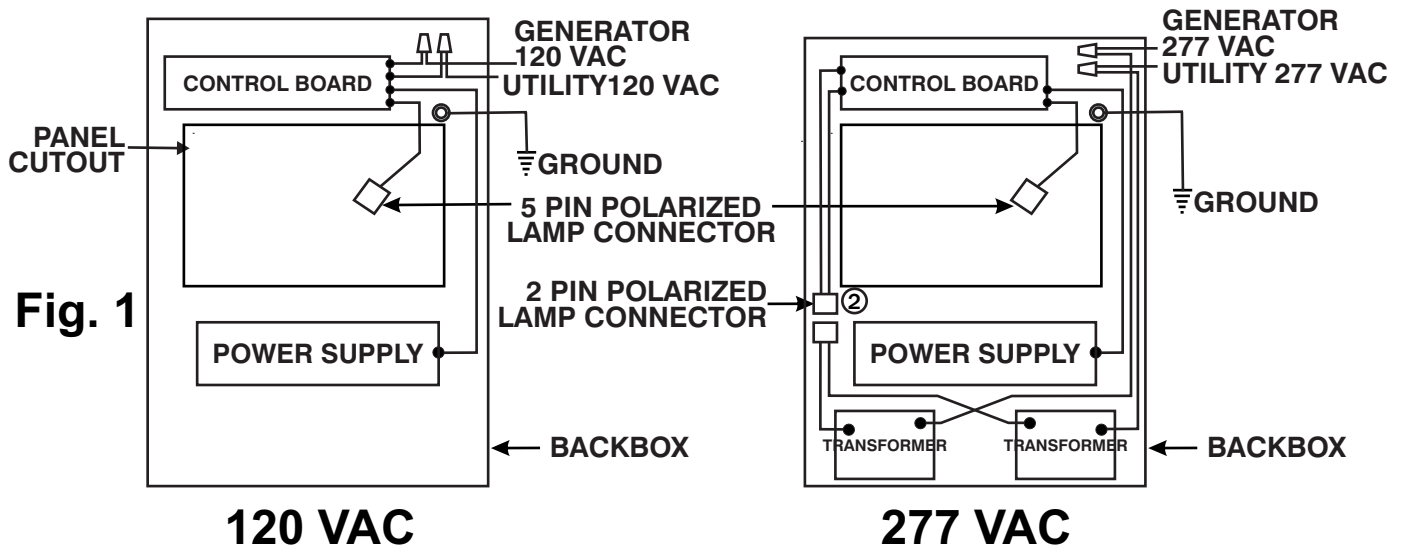

LAMP HOUSING ASSEMBLY

1. Open doors on lamp housing, remove two #8-32 bracket screws next to door hinges, and lift out Door-Lamp assembly. Remove hardware kit and lamp boxes inside.
2. Snap 5- Pin Connector from control board into opening in lamp housing. Check nylon spacers are in place on four #8-32 studs in back box, then slide lamp housing over studs until flange is flat against ceiling or wall finishing panel. Press housing firmly on to panel surface and tighten four #8-32 flange nuts supplied on to Studs.

Installation Instructions

REV 12.21.2

LAMP & DOOR ASSEMBLY

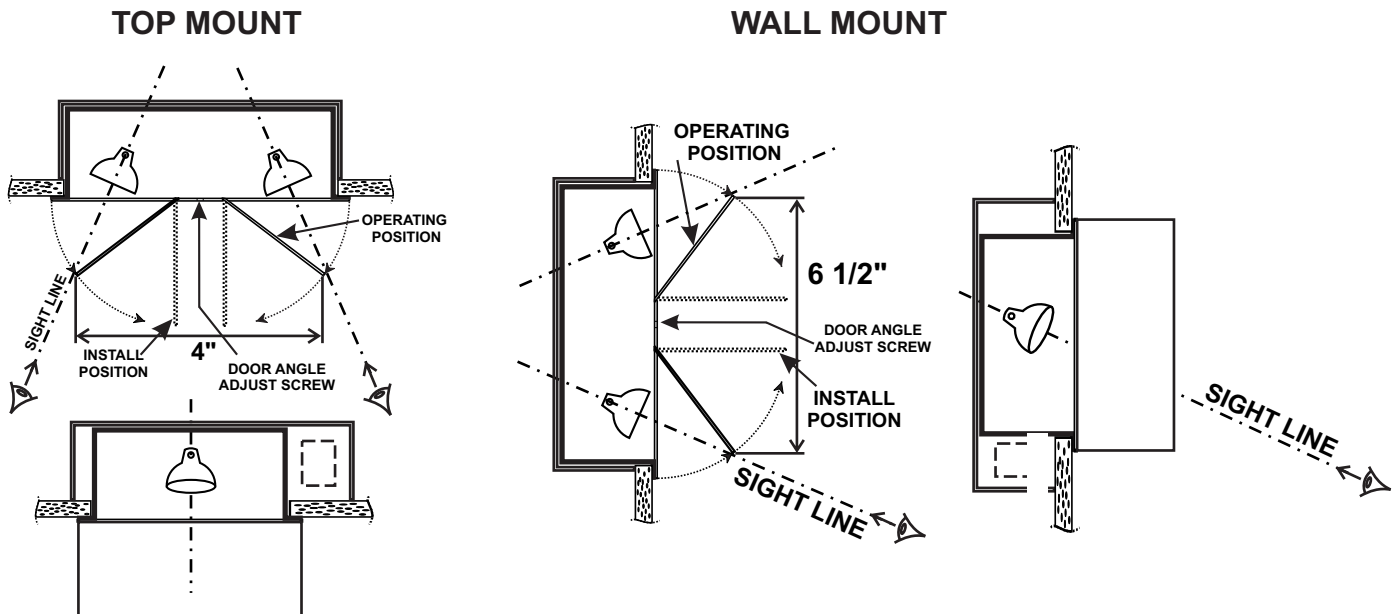

1. Insert MR16 lamps. If required, to ease lamp insertion pull wires gently away from socket to relieve spring tension on pin terminals.
2. Snap connector 1 from Door-Lamp assembly into lamp housing connector, place Door-Lamp assembly in place using pins to locate in position, and tighten two #8-32 screws.
3. Rotate lamp brackets into desired lighting position for Wall or Ceiling installations.
4. Strip off plastic protector film on mirror doors before use.

5. **FOR CORRECT LIGHT DISTRIBUTION & DOOR OPERATION, SET DOOR ANGLE BY ADJUSTING STOP SCREW USING 9 6/4" ALLEN KEY SUPPLIED, ROTATE COUNTER CLOCKWISE AS FOLLOWS:**

DIMENSION BETWEEN DOOR EDGES WHEN FULLY OPEN.

WALL MT	6 1/2"
CEILING MT	3 7/8"

6. To test fixture, turn off line power to fixture & switch to generator power.

Setup & Operation

REV 12.21.2

TROUBLESHOOTING

FAULT	CORRECTION
Lamps fail to operate when AC power is off and generator power is on.	Check lamps are fully inserted in sockets.
Doors fail to operate when AC power is off and generator power is on.	Manually open doors and confirm movement is free with no resistance. If movement is not free, check alignment of doors and hinges. Bent or buckled doors will require factory replacement. If movement is free, check terminal connectors on solenoid coil are in position and firm.
Doors do not stay closed when manually operated	Close doors electrically. Switch off AC line power, switch on generator power, then switch on AC line power to turn off generator power. After normal delay, doors will close fully.
Doors OPEN when AC power is ON	Check wire polarity connections to solenoid terminals as marked on frame: RED: POSITIVE, BLACK: NEGATIVE.

Wiring Diagram

REV 12.21.2

