

INSTALLATION INSTRUCTIONS

INSTALLATION INSTRUCTIONS FOR LED EMERGENCY UNIT

IMPORTANT SAFEGUARDS

READ AND FOLLOW ALL SAFETY INSTRUCTIONS

SAVE THESE INSTRUCTIONS AND DELIVER TO OWNER AFTER INSTALLATION

WARNING: RISK OF ELECTRIC SHOCK- NEVER CONNECT TO, DISCONNECT FROM, OR SERVICE WHILE EQUIPMENT IS ENERGIZED.

WARNING: FAILURE TO FOLLOW THESE INSTRUCTIONS AND WARNINGS MAY RESULT IN DEATH, SERIOUS INJURY OR SIGNIFICANT PROPERTY DAMAGE - For your protection, read and follow these warnings and instructions carefully before installing or maintaining this equipment. These instructions do not attempt to cover all installation and maintenance situations.

- All service shall be performed by qualified service electrician. This product must be installed and maintained in accordance with the applicable installation codes by a person familiar with the construction & operation of the product and the hazards involved.
- This product must be installed in accordance with the applicable installation codes and ordinances.
- Before wiring to power supply, turn off electricity at fuse or circuit breaker.
- Disconnect A. C. power and unplug battery before servicing.
- Consult your local building code for approved wiring and installation.
- Do not let power supply cord touch hot surfaces.
- Do not mount near gas or electric heater.
- Equipment should be mounted in locations and at heights where it will not readily be subjected to tampering by unauthorized personnel.
- The use of accessory equipment not recommended by the manufacturer may cause an unsafe condition.
- Do not use this equipment for other than intended use.
- Connect to an AC voltage as recommended on the product label of this equipment.

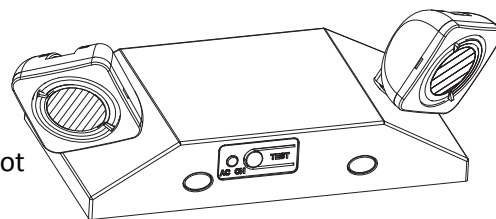

WIRING DIAGRAM:

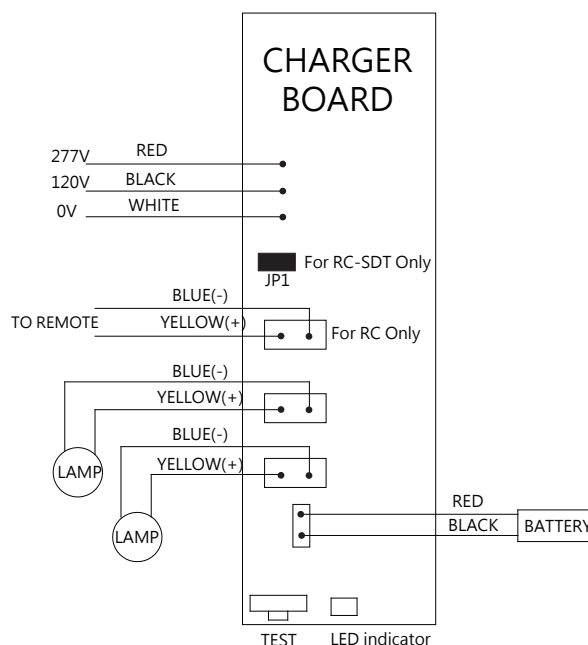

Note:

Use 18-22 AWG stranded wire to connect remote lamp heads.

Remove Jumper (JP1) from PCBA, if remote lamps are being connected (RC-SDT models only)

Unused input lead must be properly insulated with wire nut or other approved method.

CAUTION: DO NOT connect YELLOW and BLUE remote leads together. Please also ensure remote head positive (+) lead is connected to Emergency unit's yellow lead (+) and remote head negative (-) lead is connected to Emergency unit's blue lead (-).

SAVE THESE INSTRUCTIONS!

INSTALLATION INSTRUCTIONS

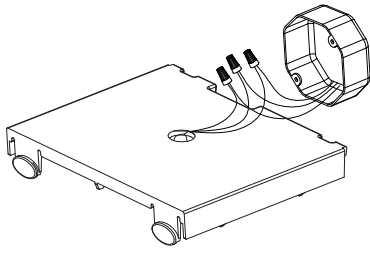

Fig.A (J-Box)

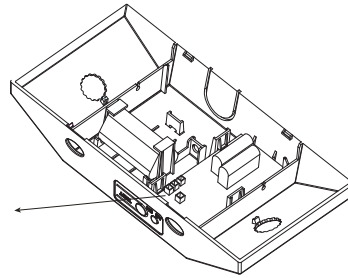
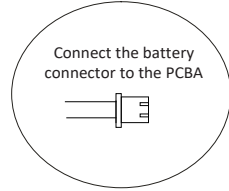

Fig.B

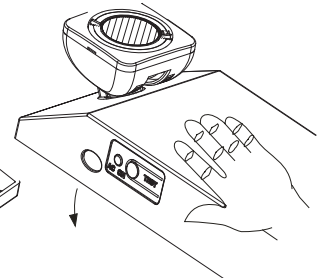

Fig.C

J-BOX MOUNTING INSTALLATION

1. Before starting installation, make sure AC power is turned OFF.
2. Remove unit's backplate by pushing through the two locking tabs at the bottom using a narrow screwdriver.
3. Feed fixture leads through the back plate and connect to AC power supply leads (Fig A). For 120V use Black & White wires and for 277V, use Red & White wires.
4. Attach back plate to J-Box (not provided) and secure with screws.
5. Complete the battery connection. (Fig. B)
6. Align tabs and push housing directly onto the back plate (Fig. C). Apply continuous AC power.
7. After the battery has been left to charge for 24 hours, test the unit by pushing the test switch and the LED lamp heads will turn ON.

CONDUIT MOUNT INSTALLATION:

1. Before starting installation, make sure AC power is turned OFF.
2. Remove unit's backplate by pushing through the two locking tabs at the bottom using a narrow screwdriver.
3. Secure back plate to wall surface using keyhole knockouts.
4. Remove the knockouts for conduit opening on the backplate and unit housing. Feed wires through the hole to make conduit connection. For 120V, use Black & White wires and for 277V, use Red and White wires.
5. Complete the battery connection. (Fig. B)
6. Align tabs and push housing directly onto the back plate (Fig. C). Apply continuous AC power.
7. After the battery has been left to charge for 24 hours, test the unit by pushing the test switch and the LED lamps heads will turn ON

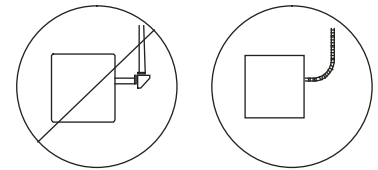

FLEXIBLE CONDUIT ONLY

OPERATION:

The battery in this unit may not be fully charged. After electricity is connected to the unit for at least 24 hours, then normal operation of this unit should take effect. To check, press the "TEST" button. The LED lamps on the unit should turn ON.

In accordance with NFPA 101, the emergency lighting system must be tested monthly for a minimum of 30 seconds and annually for 90 minutes. Refer to the local codes for any additional requirements that may apply. When re-lamping, use only LED lamps specified in the fixture. Using other lamp types may result in damage or unsafe conditions.

Note: UL recommended maximum mounting height is 16-ft

SAVE THESE INSTRUCTIONS!