

IMPORTANT SAFEGUARDS READ AND FOLLOW ALL SAFETY INSTRUCTIONS.

When using electrical equipment, basic safety precautions should always be followed including the following:

- **DISCONNECT AC POWER SUPPLY BEFORE SERVICING.**
- Installation and servicing of this equipment should be performed by qualified service personnel only.
- Ensure that the electrical wiring conforms to the National Electrical Code NEC® and local regulations if applicable.
- Do not mount near gas or electrical heaters.
- Do not use outdoors.
- Equipment should be mounted in locations and at heights where it will not be readily subjected to tampering by unauthorized personnel.
- The use of accessory equipment not recommended by the manufacturer may cause an unsafe condition.
- Any modification or use of non-original components will void the warranty and product liability.
- Do not use this equipment for other than intended use.
- Allow battery to charge for 24 hours before first use.
- For use with metal enclosed wiring systems.

SAVE THESE INSTRUCTIONS!



Wall/Ceiling Mount - Back Power Feed

1. Insert a flat blade screwdriver into the two slots to remove front cover from backplate. (Fig 1).
2. Remove knockout from center of backplate and route wires through the hole.
3. Remove appropriate knockouts on backplate and mount to junction box.
4. Connect the fixture wires to the power supply wires using the wire nuts provided. Connections should be made inside junction box. Connect the white wire to neutral and black wire to the hot lead. Refer to **Wiring Diagram** section.
5. Connect remote lamp wires if fixture is remote capable. Refer to **Remote Lamp Connection** section.
6. Connect battery to PCB.
7. Snap the front cover on the backplate.
8. Restore power and then test fixture by pressing test button. LED heads will turn on.
9. Adjust the direction of lamp heads for optimal lighting coverage.

Wall Mount - Top Power Feed

1. Insert a flat blade screwdriver into the two slots to remove front cover from backplate.
2. Remove top knockout on the top flange of fixture for the flexible conduit access hole.
3. Secure flexible conduit to access hole and route wires through conduit to junction box. (Fig. 3)
4. Remove appropriate knockouts from backplate and mount to wall.
5. Connect the fixture wires to the power supply wires using the wire nuts provided. Connections should be made inside junction box. Connect the white wire to neutral and black wire to the hot lead. Refer to **Wiring Diagram** section.
6. Connect remote lamp wires if fixture is remote capable. Refer to **Remote Lamp Connection** section.
7. Connect battery to PCB.
8. Snap the front cover on the backplate.
9. Restore power and then test fixture by pressing test button. LED heads will turn on.
10. Adjust the direction of lamp heads for optimal lighting coverage.

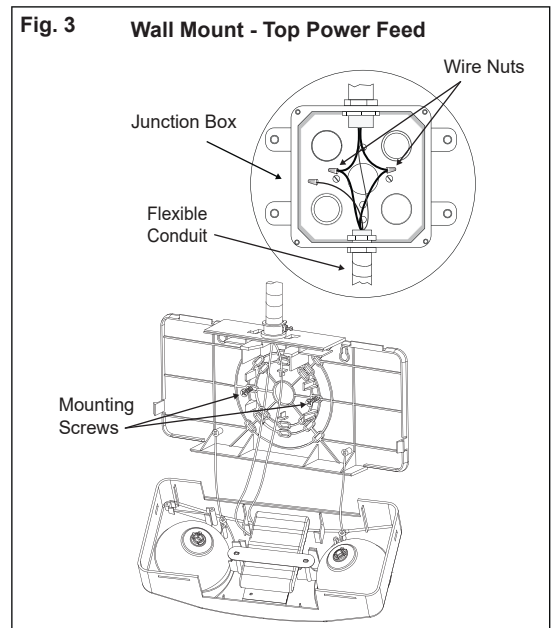
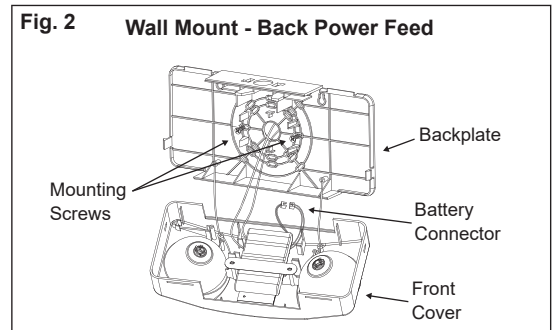
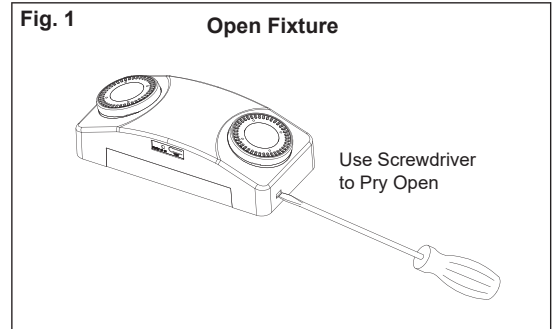

Remote Lamp Connection - 9V, 5.4W Max (Option)

1. Remove ground male connector from the female connector.
2. Plug the remote male connector into the female connector.
3. Connect extended remote head wires to the remote wires using wire nut.
Yellow positive (+)
Purple negative (-)

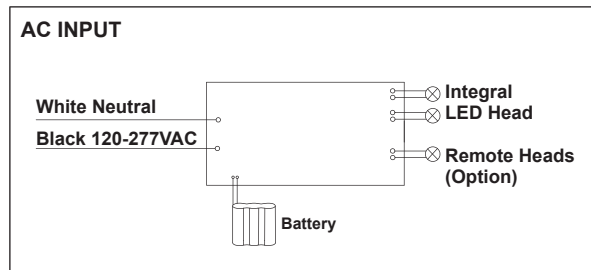
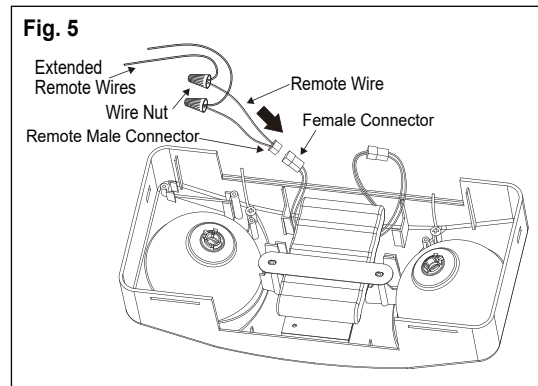
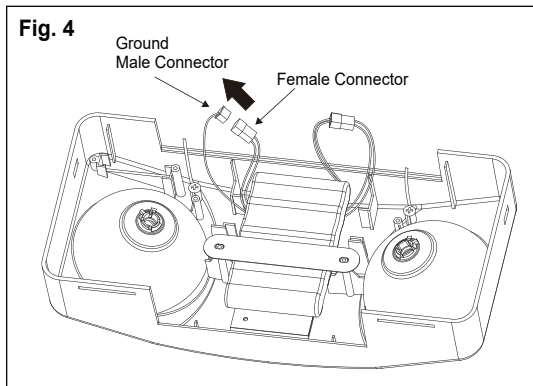

Self-test/Self-diagnostics Option

1. When AC power is supplied to fixture, the unit will automatically initiate a Self-test/Self-diagnostic as follows:

- Verifies battery disconnection, charger board failure, lamps failure and transformer failure at every 5 seconds.
- 3 Minute Self-testing every month.
- 90 Minutes Self-testing on the 12th month of the year after installation.

2. Dual color LED lamp indicator shows the following status:

- Green color: ON/ Ready
Blinking: Testing
- Red color (Service Alert)
- Service Alert LED Code (Red color LED lamp indicator)

One blink ON/pause for 4 seconds	Battery is not connected
Two blinks ON/pause for 4 seconds	Battery is shorted or battery voltage drops below acceptable level
Three blinks ON/pause for 4 seconds	Charger board circuit fault
Four blinks ON/pause for 4 seconds	Transfer fault
Five blinks ON/pause for 4 seconds	Emergency lamp fault
Six blinks ON/pause for 4 seconds	Remote head's emergency lamp fault (if installed)

CAUTION:

After solving the fault of emergency equipment, please press test button for 2 seconds without releasing to reset. LED indicator will show green.

3. For manual test, press test button as follows:

Press test button once within 2 seconds	30 Second test
Press test button twice within 2 seconds	3 Minute test
Press test button 3 times within 2 seconds	30 Minute test
Press test button 4 times within 2 seconds	90 Minute test