

## IMPORTANT SAFEGUARDS READ AND FOLLOW ALL SAFETY INSTRUCTIONS.

When using electrical equipment, basic safety precautions should always be followed including the following:

- **DISCONNECT AC POWER SUPPLY BEFORE SERVICING.**
- Installation and servicing of this equipment should be performed by qualified service personnel only.
- Ensure that the electrical wiring conforms to the National Electrical Code NEC® and local regulations if applicable.
- Do not mount near gas or electrical heaters.
- Do not use outdoors.
- Equipment should be mounted in locations and at heights where it will not be readily subjected to tampering by unauthorized personnel.
- The use of accessory equipment not recommended by the manufacturer may cause an unsafe condition.
- Any modification or use of non-original components will void the warranty and product liability.
- Do not use this equipment for other than intended use.
- Allow battery to charge for 24 hours before first use.
- For use with metal enclosed wiring systems.

## SAVE THESE INSTRUCTIONS!

## Recessed Ceiling or Recessed Wall Mount

- Position the recessed kit between the joists (Fig. 1).  
**NOTE:** If using a single face EXIT sign, make sure to position the recessed kit such that when the EXIT panel assembly is installed, it will be in the correct orientation. This is determined by matching up the location of the EXIT panel connector within the trim plate assembly (see Fig. 2) and the location of the EXIT panel connector on the EXIT panel (see Fig. 3 & 4).
- Align one end of the bar hangers with the bottom of the joists, then secure temporarily by hammering in the “nail-in” tabs. Loosen the bar hanger set screws on both sides of the recessed housing. Align the other end of the bar hangers to the opposing joist and hammer in the “nail-in” tabs.
- Once the bar hangers are aligned properly, permanently secure the bar hangers by hammering in the nails.
- With the bar hanger set screws still loose, adjust the horizontal placement of the recessed housing between the joists by sliding along the bar hangers. Secure by tightening the bar hanger set screws.
- Adjust the vertical placement of the recessed housing by loosening the vertical slot set screws, then raising or lowering the recessed housing. The recessed housing should be positioned such that the trim plate will be flush with the ceiling or wall when installed. Secure by tightening the vertical slot set screws.
- Separate the trim plate assembly from the housing by loosening the (2) screws on either end of the trim plate. The spring hangers will keep the trim plate assembly from falling (Fig. 2).
- Loosen the end of the trim plate assembly closest to the wire compartment by pinching the spring hanger and guiding its ends out through the opening in the housing. Carefully lower the loosened end of the trim plate assembly until it is supported by the safety cable.
- Connect the battery/batteries to the PCB.
- Remove the wire compartment cover and set aside.
- Route wires into the wire compartment.
- Make electrical connections; see **Electrical Connections** section.
- Push excess wire into the wire compartment, then replace the wire compartment cover.
- Reposition the spring hanger into the recessed housing, then slide the trim plate assembly back into the recessed housing and secure with the (2) screws.
- Connect the EXIT panel assembly to the PCB, then secure by sliding into the EXIT panel slot in the trim plate (Fig. 3 & 4).

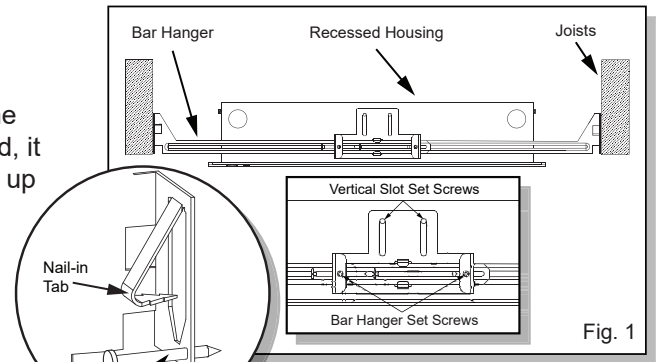

Fig. 1

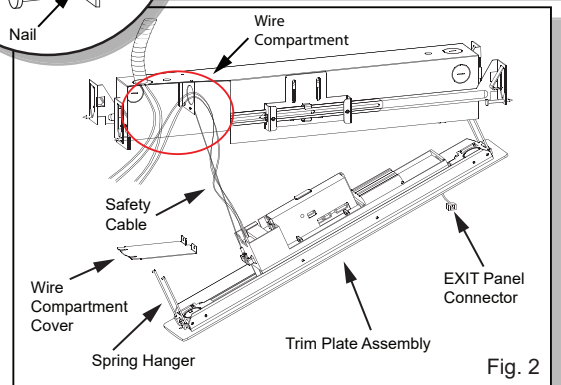

Fig. 2

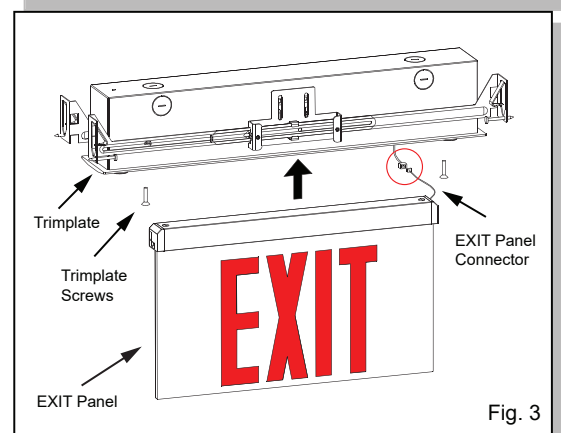

Fig. 3

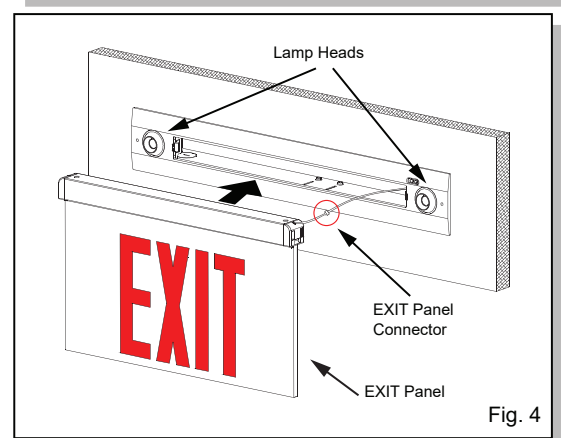

Fig. 4

## Surface Ceiling or Surface Wall Mount

1. Attach the adjustable crossbar to the J-box using the (2) 8-32 x 1" screws (supplied). Use the slotted portion of the adjustable crossbar to mount to the J-box and position such that the portion with the threaded holes is facing out from the J-box (Fig. 1).
2. Punch out the desired knockouts located in the top or side of the housing for ceiling or wall mounting, respectively. Insert the plastic grommet (supplied) into the center hole.
3. Attach the canopy to the housing using the (2) M4 x 8mm screws (supplied).
4. Insert the (2) plastic rivets (supplied) into the (2) unused M4 holes in the housing.
5. Remove one of the housing end plates and set aside. Slide out the trim plate assembly from the housing.
6. Connect the battery/batteries to the PCB.
7. Slide the trim plate assembly partially into the housing so that the wires can be routed through the canopy, then route the wires through the canopy.
8. Slide the trim plate assembly fully into the housing and remove the excess slack from the wires inside the housing by pulling them farther out through the canopy. Replace the end plate and secure with the (4) screws, it is recommended to hand tighten or use a low torque driver to avoid stripping the screws.
9. Make electrical connections; see **Electrical Connections** section.
10. Secure the unit to the adjustable crossbar using the (2) M4 x 40mm screws (supplied). Ensure the canopy is securely fastened against the ceiling or wall and will not rotate.
11. Connect the EXIT panel assembly to the PCB, then secure by sliding into the EXIT panel slot in the trim plate (Fig. 2).

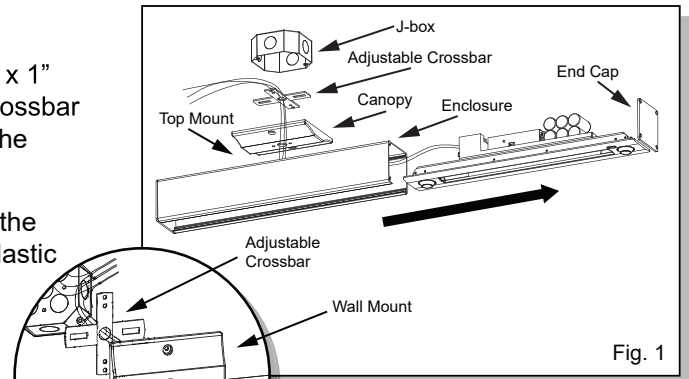

Fig. 1

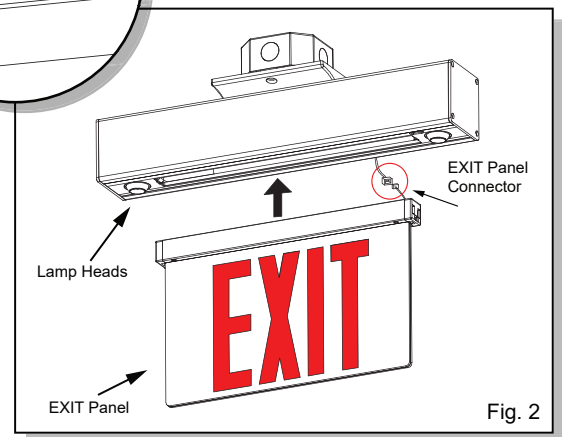

Fig. 2

## Remote Lamps

If the unit is installed with the remote capable option, the unit can support 3.6V 2.8W max. remote capabilities.

To connect the remote heads to the unit, connect the remote wires to the remote connector. Yellow is positive (+) and purple is negative (-).

The remote connector connects to the female connector on the PCB labeled RH1.

---

## Electrical Connections

Make electrical connections as follows:

120VAC	277VAC
White - Common	White - Common
Black - 120VAC	Orange - 277VAC

**Note:** Cap unused wires to prevent shorting.

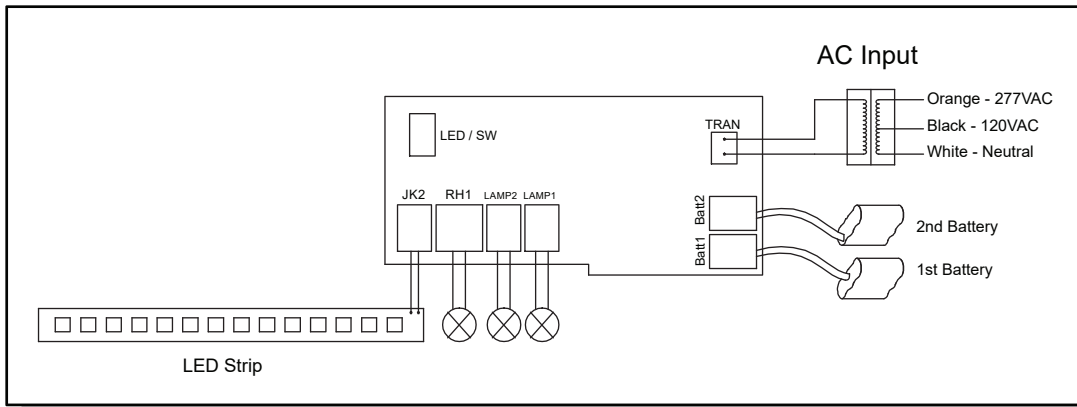

---

## Self-test/Self-diagnostics (SD)

### Operation

The purpose of this option is to provide Self-testing and Self-diagnostic capabilities to the EXIT sign. At predetermined intervals, the EXIT sign will automatically switch into battery mode. Refer to the Self-test section of this page for timing details. The EXIT sign will also perform various Self-diagnostic tests of the unit. The circuitry continuously monitors the operating condition of the EXIT sign and battery charging circuit. Visual signaling will alert maintenance personnel to a fault of the EXIT sign electronics, emergency lamps, battery, and/or battery charger. Refer to the LED Indicator section below for fault reporting details.

### LED Indicator

The unit is equipped with a bi-color LED, which displays either green or red.

- A steady green LED indicates that normal AC power is being supplied to the EXIT sign.
- A flashing green LED indicates that the unit is undergoing a test.
- A blinking red LED indicates whenever the Self-diagnostic system has detected a fault condition. Refer to the chart below when the LED is blinking red:

Number of Blinks	Unit Fault	Corrective Action
1	Battery is Disconnected	Check Battery Connections
2	Battery	Replace Battery
3	Charge	Charger board circuit fault
4	Transfer (AC to DC)	Transfer function failure
5	Emergency Lamp	Check Lamp Connections Then Consult Factory
6	Remote Lamp	Check Remote Lamp Connections Then Consult Factory
7	EXIT Panel	Check EXIT Panel Connections Then Consult Factory

### Self-test Features

- The EXIT sign will automatically switch to battery mode every month for a period of 1 minute.
- The EXIT sign will automatically switch to battery mode every 6 months for a period of 30 minutes.
- The EXIT sign will automatically switch to battery mode every 12 months for a period of 90 minutes.

### Test Button Features

MANUAL TEST – Pressing the test button will switch the unit into battery mode for a set amount of time. The desired length of the test is determined by the number of times the test button is pressed.

- Pressing the test button once will switch the unit into battery mode for a period of 30 seconds.
- Pressing the test button twice within 2 seconds will switch the unit into battery mode for a period of 3 minutes.
- Pressing the test button 3 times within 2 seconds will switch the unit into battery mode for a period of 30 minutes.
- Pressing the test button 4 times within 2 seconds will switch the unit into battery mode for a period of 90 minutes.

RESET – Pressing and holding the test button for 2 seconds will reset the LED to a steady green. If multiple faults are present, it may be necessary to repeat this procedure for each remaining fault indicated by the blinking red LED.

Use in accordance with local building codes