Instructions IMPORTANT SAFEGUARDS

When using electrical equipment, basic safety precautions should always be followed including the following:

1. **READ AND FOLLOW ALL SAFETY INSTRUCTIONS**
2. Disconnect power before performing work on electrical equipment.
3. Do not use outdoors.
4. Do not let power cords touch hot surfaces and do not mount near gas or electric heaters.
5. Use caution when servicing batteries. Battery acid can cause burns to skin and eyes. If acid is spilled on skin or eyes, flush with fresh water and contact a physician immediately.
6. Equipment should be mounted in locations and at heights where unauthorized personnel will not readily subject it to tampering.
7. The use of accessory equipment not recommended by EELP, Inc. may cause an unsafe condition, and will void the unit's warranty.
8. Do not use this equipment for other than its intended purpose.
9. Servicing of this equipment should be performed by qualified service personnel.
10. **SAVE THESE INSTRUCTIONS!**

INSTALLATION

RECESSED MOUNT - SINGLE FACE:

1. Extend unswitched 48 hour AC supply of rated voltage to junction box or appropriate wiring (supplied by others). Leave at least eight (8) inches of slack wire. The circuit should not be energized at this time.
2. Remove the exit sign faceplate by unscrewing the 4 faceplate cover screws (Figure 1).
3. Knock out the appropriate mounting pattern and/or wire pass-thru hole on the exit back plate to fit the junction box or wiring connector being used (supplied by others).
4. Bring wires through the back of the sign and mount the exit securely in place. Screw directly to junction box if possible.
5. Connect power supply as shown in Figure 3.
Insulate unused wire! CAUTION! - Failure to insulate unused wire may result in a shock hazard or unsafe condition as well as equipment failure.
6. Route wires and secure them in place.
7. For self-powered units, insert test switch with nut and AC ON indicator (Figure 4) into the exit face as shown in Figure 5.
8. Remove any directional chevron arrows to be indicated as required from the exit stencil.
9. Replace the exit faceplate together with red fibre and secure with the faceplate cover screws.
10. Turn on the AC voltage supply.

SELF-POWERED:

1. For models EAR-EM plug the battery into the circuit board per (Figure 3) self-powered sign.

CAUTION

This equipment is furnished with a sophisticated low voltage battery dropout circuit to protect the battery from over-discharge after it's useful output has been used. Allow 48 hours recharge time after installation or power failure for full load testing.

MAINTENANCE

1. The equipment is to be repaired whenever the equipment fails to operate as intended during the duration test. Written records of test results and any repairs made must be maintained. EELP, Inc. strongly recommends compliance with all Code requirements.
2. The lamps listed herein when used according to the instructions with this unit are in accordance with the requirements of CSA Standard C22.2, No. 141 – Unit Equipment for Emergency Lighting.
3. Clean exit face on a regular basis.

NOTE: The servicing of any parts should be performed by qualified service personnel only. The use of replacement parts not furnished by EELP, Inc., may cause equipment failure and will void the warranty.

TROUBLESHOOTING

LEDS DO NOT COME ON AT ALL

1. Check AC supply be sure unit has 48 hour AC supply (unswitched).
The AC supply must be at least 80% of nominal (96V on a 120V line) for equipment to function normally.
At lower voltages the LED lamps will begin to glow dimly until the source voltage drops below the full "turn on" point.
NOTE: This condition may also be caused by incorrectly connecting an AC Volt supply line to the lead.
2. Check all AC connections
3. AC supply is OK, replace LED Board Assembly.

Figure 1

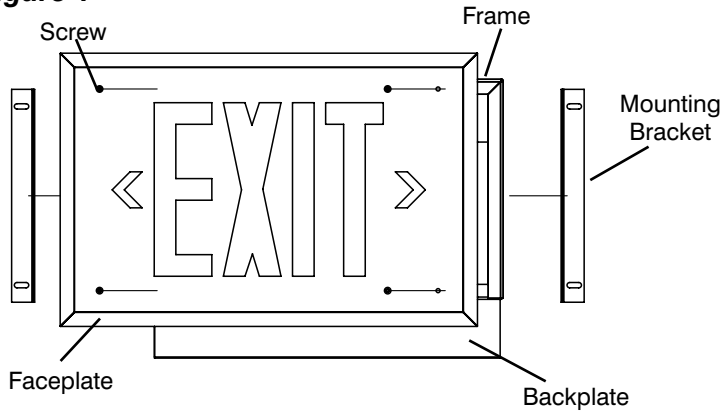

Figure 2

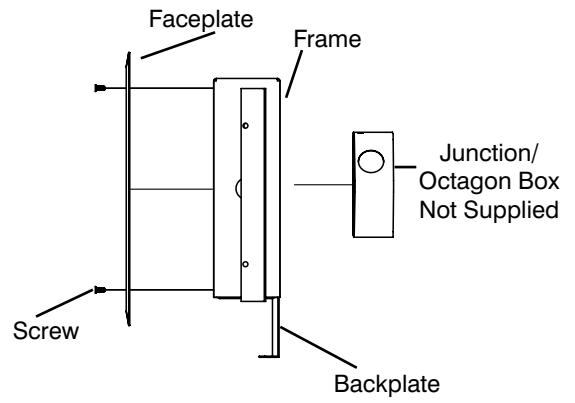

Figure 3

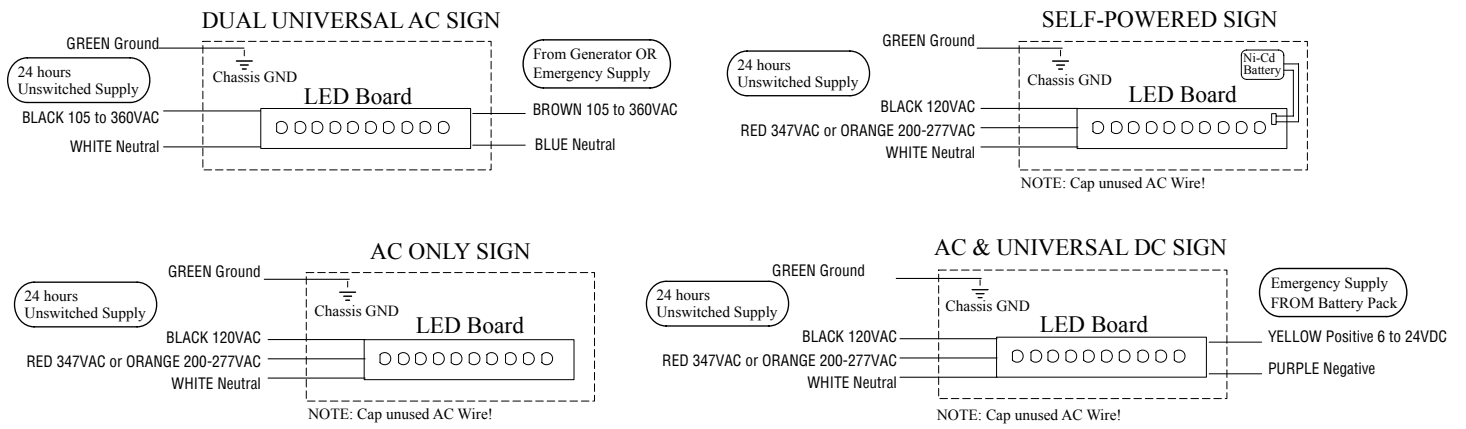
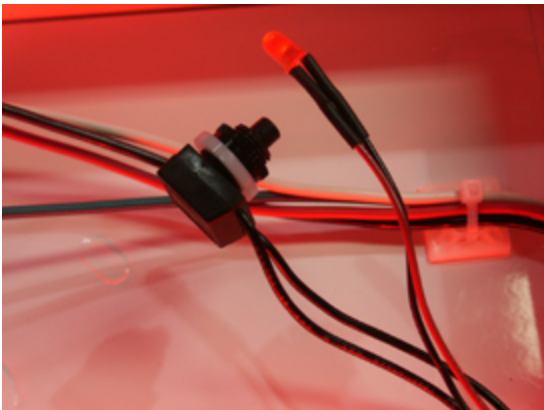

Figure 4



(self-powered units only)

Figure 5



(self-powered units only)