



DVS SERIES LED LANE CONTROL SIGNS

IMPORTANT SAFEGUARDS SAVE THESE INSTRUCTIONS

Do not mount near gas or electric heaters. Equipment should be mounted in locations and at heights where it will not readily be subjected to tampering by unauthorized personnel. The use of accessory equipment is not recommended by the manufacturer and may cause an unsafe condition. Do not use equipment for other than intended use.

WARNING: Installation and Servicing should be performed by qualified service personnel only!

**WARRANTY
5 YEAR LIMITED**

Recessed-Mount Installation Instructions

1. Use dimensions on back page to determine size of opening needed to recess sign.
2. Remove the four (4) screws from the sides of the Enclosure and remove the Backplate.
3. Disconnect Transformer from LED Panel.
4. Secure Flushmount Bezel to Enclosure using mounting holes located in Bezel tabs. **CAUTION:** Use care to avoid damaging internal components when drilling holes in Enclosure.
5. Make electrical connections in accordance with local regulations (See Wiring Diagrams on back page) using knockout provided in Backplate.
6. Re-connect Transformer to LED Panel and secure Enclosure to Backplate using the four (4) screws.
7. Secure recessed unit to exterior of wall using mounting holes provided on Bezel. Additional holes can be drilled into Bezel if needed.
8. **USE A WATERPROOF CAULK TO SEAL THE FLUSHMOUNT BEZEL TO THE WALL.**

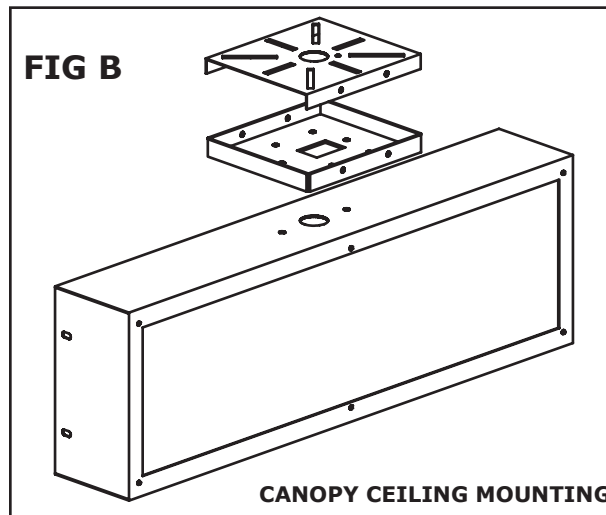
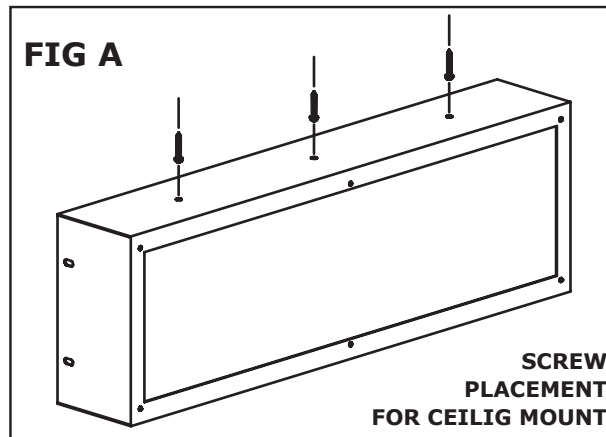

Enclosure Wall-Mount Instructions

1. Turn off power to building supply wires before beginning installation.
2. Remove the four (4) screws from the sides of the Enclosure and remove the Backplate.
3. Disconnect Transformer from LED Panel.
4. Mount Backplate directly to wall or junction box.
5. Make electrical connections in accordance with local regulations (See Wiring Diagrams on back page) using knockout provided in Backplate.
6. Re-connect Transformer to LED Panel and secure Enclosure to Backplate using the four (4) screws.
7. **USE A WATERPROOF CAULK TO SEAL THE BACK OF THE ENCLOSURE TO THE WALL.**
8. Make sure the two (2) 1/4" drain holes on the bottom of the Enclosure are not obstructed.

Enclosure Ceiling-Mount Instructions (Fig A)

1. Turn off power to building supply wires before beginning installation.
2. Remove the four (4) screws from the sides of the Enclosure and remove the Backplate.
3. Disconnect Transformer from LED Panel.

IF USING OPTIONAL CANOPY PLEASE SKIP TO STEP A BELOW

4. Mount Enclosure to ceiling, securing it with at least one (1) screw every six (6) inches along the middle of the top of the Enclosure. (See Fig A).
5. Make electrical connections in accordance with local regulations. (See Wiring Diagrams on back page.)
6. Reconnect Transformer to LED Panel and secure Enclosure to Backplate using the four (4) screws.
7. **USE A WATERPROOF CAULK TO SEAL THE BACK OF THE ENCLOSURE TO THE WALL.**
8. Make sure the two (2) 1/4" drain holes on the bottom of the Enclosure are not obstructed.

Enclosure Canopy-Mount Instructions (Fig B)

1. Turn off power to building supply wires before beginning installation.
2. Mount Canopy to Enclosure.
 - a. Drill (2) 3/16" holes for mounting screws
 - b. Drill (1) 7/8" hole for conduit
3. Secure Mounting Plate to ceiling or junction box.
4. Make electrical connections in accordance with local regulations. (See Wiring Diagrams on back page.)
5. Secure Canopy/Enclosure assembly to Mounting Plate using the four (4) screws provided.
6. Reconnect Transformer to LED Panel and secure Enclosure to Backplate using the four (4) screws.
7. **USE A WATERPROOF CAULK TO SEAL THE CANOPY TO THE ENCLOSURE AND THE CEILING, AND TO SEAL THE BACKPLATE TO THE ENCLOSURE.**
8. Make sure the two (2) 1/4" drain holes on the bottom of the Enclosure are not obstructed.

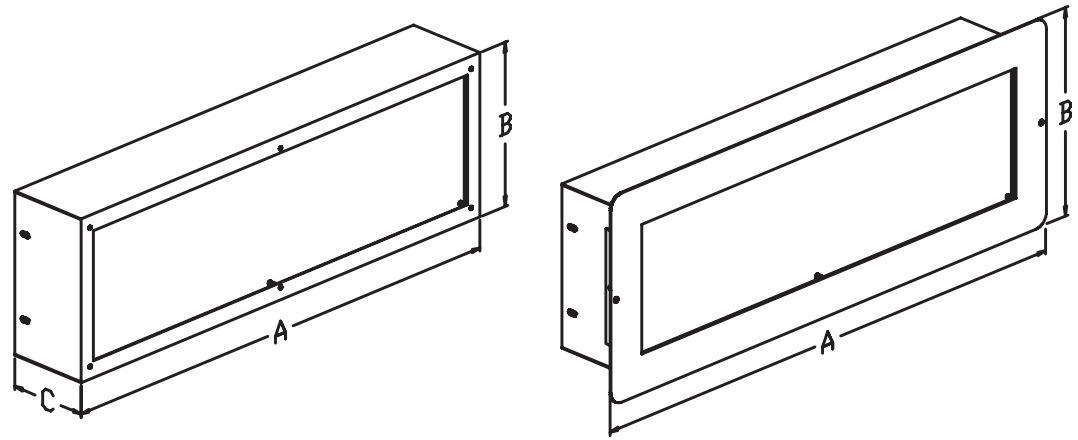
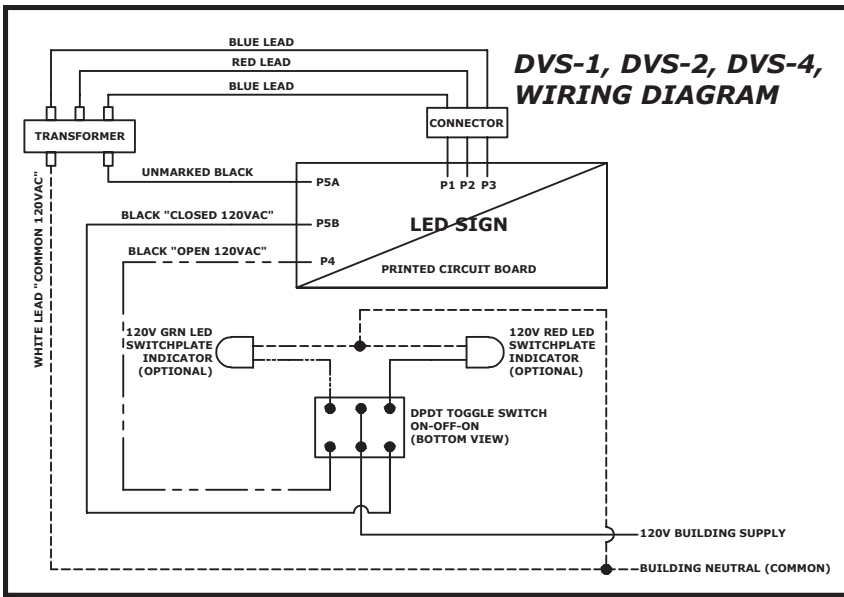

Enclosure Dimensions

	A	B	C
DVS-1	32.625	6.000	3.250
DVS-2	17.875	11.625	3.250
DVS-4	14.000	14.000	3.250
DVS-3	19.500	6.250	3.250

Flushmount Bezel Dimensions

	A	B	C
DVS-1	34.625	8.000	-
DVS-2	19.875	13.625	-
DVS-4	15.750	15.750	-
DVS-3	21.300	7.940	-

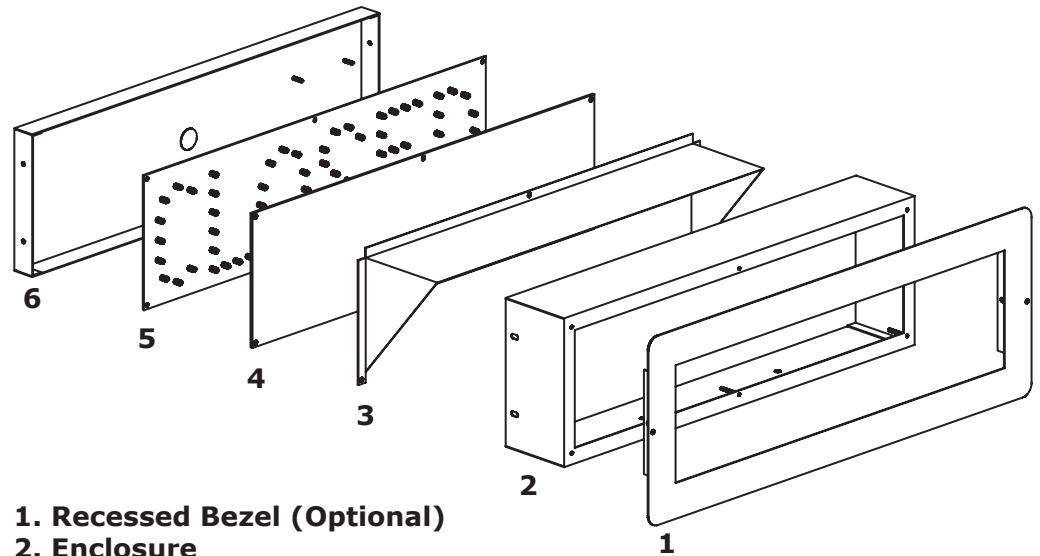
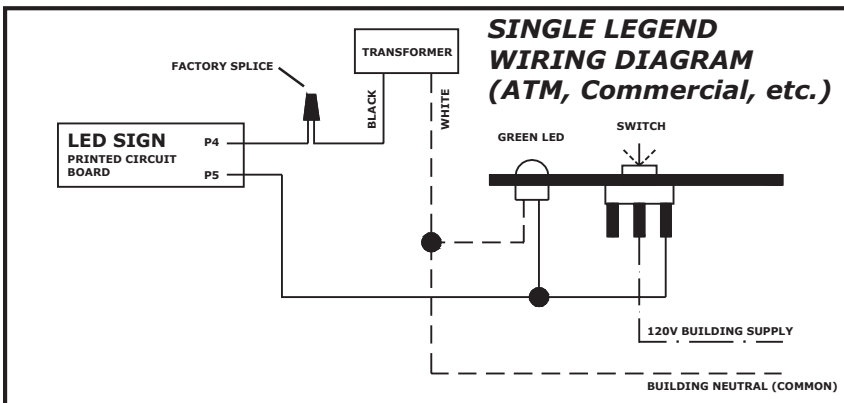
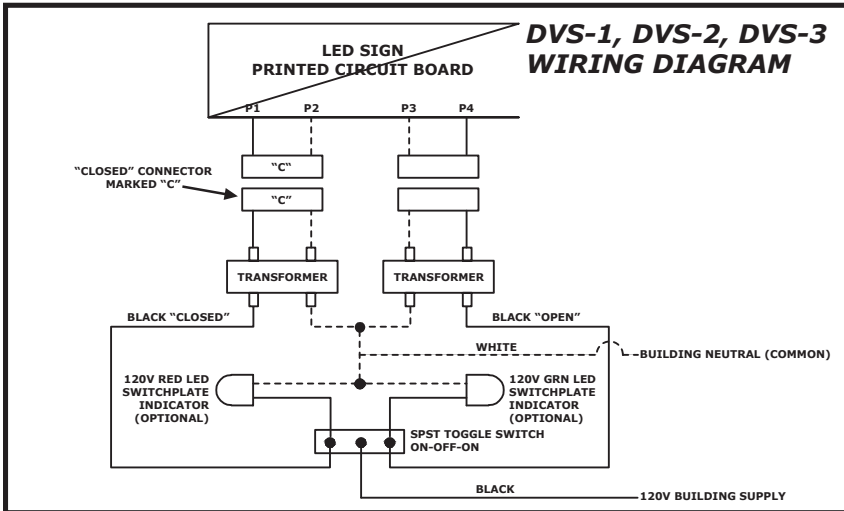

1. Recessed Bezel (Optional)
2. Enclosure
3. Visor (Optional)
4. Dust Cover
5. LED Panel
6. Backplate