

INSTALLATION INSTRUCTIONS

CHICAGO APPROVED LED EMERGENCY UNIT

READ AND FOLLOW ALL SAFETY INSTRUCTIONS

CAUTION: The battery in this unit may not be fully charged. After electricity is connected to unit, let battery charge for at least 24 hours, then normal operation of this unit should take effect. To check, press the TEST button. The lamps on the unit should turn on.

IMPORTANT SAFEGUARDS: When using electrical equipment, basic safety precautions should always be followed, including the following:

1. Consult local building code for approved wiring and installation.
2. Disconnect AC power before servicing and installation.
3. Do not mount near gas or electric heaters.
4. Do not use outdoors.
5. Do not use this equipment for anything other than its intended use.
6. The use of accessory equipment not recommended by the manufacturer will void product listing and warranty and may cause an unsafe condition.
7. Any service on this equipment should be performed by qualified personnel only.
8. Equipment should be mounted in locations and at heights where it will not be subject to tampering by unauthorized personnel.
9. Use caution when servicing batteries.
10. Cap unused wires with enclosed wire nuts or other approved method.
11. Make sure wire terminations are secure and leads are properly tucked in appropriate wire channels.

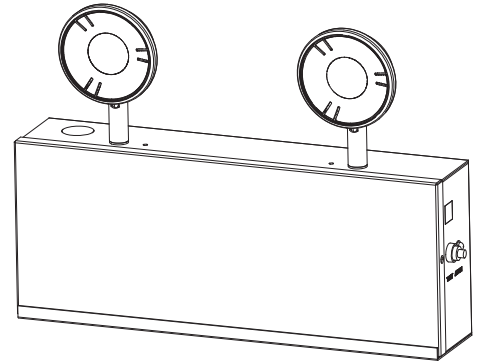

INSTALLATION:

1. Remove the front cover. When required, remove battery to access J-Box mounting holes.
2. Mount the equipment securely in place on the wall. Two additional 'Key Hole' mounting holes are located at the top of the unit housing in addition to the 'J-Box' mounting holes. These '2' additional mounting slot holes must be used when the unit is mounted to the wall. Additional chain support may be required by local codes. Chain hook holes are provided at each end of the enclosure.
3. Extend 24 hr AC supply of rated voltage to the equipment, which is furnished with a dual voltage (120/277V) field selectable input. Connect unit to utility power using an approved connector. For 120V supply, connect the line wire to the black lead of the unit. For 277V supply, connect the line wire to the orange lead of the unit. Connect neutral wire to the white lead. The ground wire (green lead) needs to be connected in accordance with the local codes. DO NOT energize the circuit at this time. (CAUTION: Insulate the unused black or orange lead. Failure to do so may cause an unsafe condition)
4. If remote fixtures are to be connected to the equipment extend the remote circuit in accordance with Article 700 and 720 of the National Electric Code (NEC) and connect the yellow and blue leads coming out of the unit. (CAUTION: The minimum wire size required by the NEC is 12 gauge Copper or equivalent. Your installation may require larger sized wire to ensure that the voltage drop DOES NOT exceed 5%. Do not exceed the total output rating of the equipment including any additional mounted heads.
5. Install and connect the battery. Refer to the Illustration. Connect the RED(+) lead from the PC board assembly to the positive (+) terminal on the battery and Black (-) lead from the PC board assembly to the negative (-) terminal. (CAUTION: Observe polarity) Failure to connect the battery properly will result in equipment failure and an unsafe condition. NOTE: The Emergency lights will NOT come ON at this time.
6. Energize the unit with AC supply. The charge indicator will illuminate.
7. Replace the unit cover.
8. Adjust and focus the lighting heads as required.

SAVE THESE INSTRUCTIONS!

INSTALLATION INSTRUCTIONS

CHICAGO APPROVED LED EMERGENCY UNIT

TESTING:

National Electric Code (NEC) and NFPA life safety code regulations require that routine tests need to be performed as listed below: Once every month, the unit needs to be tested for duration of 30 seconds. Push in and hold the test switch to perform this test. Once every 12 months, a full 90-minute test (per UL requirements) needs to be performed on the unit. Disconnect power to the unit and leave it in the emergency mode. The lamps should stay ON for at least 90 minutes.

TROUBLE - SHOOTING:

Condition - The emergency lights do not operate

1. If the charge indicator light is off: Check that the circuit breaker for AC supply is ON.
2. If the charge indicator light is ON: Check that battery is properly connected. If problem persists, Replace battery.
If remote lamps are connected to the equipment, then turn OFF the AC supply and disconnect the remote circuit wires from the equipment. Turn ON the AC supply and depress the test switch. If the local lamps (mounted on the equipment itself) come ON, then check the remote circuit for short or overload condition and correct as required. Reconnect the circuit wires and restore AC power. If the local lamps don't turn ON after disconnecting the remote circuit wires, then replace battery.

Condition - Emergency lights are dim

1. Battery not fully charged. Allow battery to recharge for 24 hours and then retest. If lights are still dim, replace battery.

OPERATION:

1. Apply AC power to the unit. The LED indicator should turn GREEN. If it shows RED, then it implies that the battery is disconnected or needs to be replaced.
2. After the battery has been left to charge for (24) hours, test the unit by pressing the switch. The LED indicator turns OFF and the lamps on the unit turn ON.
3. When the switch is released, the lamps turn OFF and the LED indicator turns GREEN.

MAINTENANCE:

Caution: Always turn off AC power to the equipment before servicing. Servicing should be performed only by a qualified service technician. Use only MANUFACTURER supplied replacement parts.

1. BATTERY: The battery supplied in this equipment requires no maintenance. However, it should be tested periodically (see TESTING) and replaced when it no longer operates the connected fixtures for the duration of a 30-second or 90-minute test. The battery supplied in this equipment has a life expectancy of 5-7 years when used in a normal ambient temperature of 72°F.
2. OTHER: Clean lamphead lenses and/or replace as and when required.

NOTE: UL recommended maximum mounting height is 36-ft.

Wiring Diagram:

